

# VENT HOLE SCRAPER TOOL

Fouling can accumulate in the tiniest of places, such as the area where the gas tube enters the upper receiver in an MSR/AR rifle. Prevent oil blowback by properly cleaning this area with the AR vent hole scraper.

1. Attach tool to front end of charging handle and rotate tool 90 degrees to lock in place.

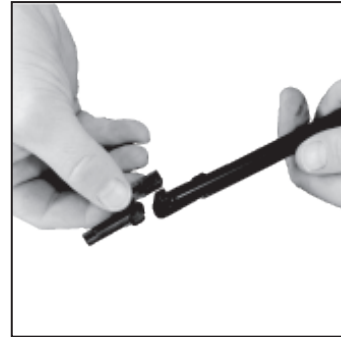

2. Insert charging handle with attached tool back in normal position in upper receiver. When fully seated, tool will clean out vent hole area.

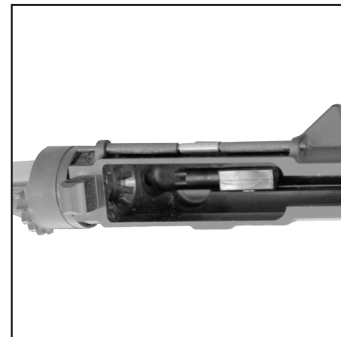

3. Remove charging handle and tool from upper receiver.

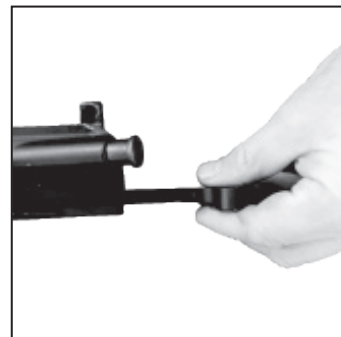

4. Rotate tool 90 degrees to unlock from charging handle.

